

Type SB4 Load Cell



Flintec load cells are designed to meet the most stringent accuracy requirements. Certifications have been obtained from Weights & Measures Authorities, worldwide.

SB4 load cells are available in the capacities 5 kN to 100 kN (510 kg to 10197 kg) and include Accuracy Classifications GP, C1, C3, C3 MI 7.5, C4 and C4 MI 7.5 according to OIML R 60; NTEP $n_{max}=5000$.

They offer total stainless steel construction and complete hermetic sealing, making them suitable for use in the toughest industrial environments.

The unique “blind” loading hole combined with the available Flintec loading hardware provides an excellent price-performance ratio.

It allows very low profile platform design and offers advantages in all kinds of weighing applications.

The Flintec calibration technique (in $mV/V/\Omega$) eliminates time consuming corner calibration in multiple load cell systems.

The SB4 is available for use in hazardous areas zone 1, 2 (gas) and 21, 22 (dust) according to EEx ia IIC T6...T4 T130°C ATEX.

Important Features

- Capacities: 5 kN to 100 kN.
- High accuracy.
- Total stainless steel construction.
- Complete hermetic sealing.
- Protection IP 68.
- Low profile.
- High input resistance: 1100 Ω .
- W&M certified for 4000 intervals.
- Multi range and multi interval accuracy.
- Unique “blind” loading hole.
- Calibration in $mV/V/\Omega$.
- Easy cable replacement.
- Complete range of loading hardware available.
- Factory mutual approved.

Option

- Ex-version zone 1, 2, 21 and 22 ATEX.

SB4 Specifications

Maximum capacity (=E _{max})	kN	5 / 10 / 20 / 50 / 100					5 / 10 / 20 / 50	
Metric equivalents (1 N=0.10197 kg)	kg	510 / 1020 / 2039 / 5099 / 10197					510 / 1020 / 2039 / 5099	
Rated Output (=RO)	mV/V	2 ± 0.1%						
Calibration in mV/V/Ω (A...I classified)	%RO	≤ ± 0.05 (≤ ± 0.005)						
Accuracy class according to OIML R 60		(GP)	C1	C3	C3 MI 7.5	C4	C4 MI 7.5	
Maximum number of verification intervals (n)		n.a.	1000	3000	3000	4000	4000	
Minimum load cell verification interval (v _{min})		n.a.	E _{max} /5000	E _{max} /11000	E _{max} /11000*	E _{max} /11000	E _{max} /11000	
Combined error	%RO	≤ ± 0.040	≤ ± 0.030	≤ ± 0.020	≤ ± 0.020	≤ ± 0.018	≤ ± 0.018	
Creep error (30 minutes)	%RO	≤ ± 0.060	≤ ± 0.049	≤ ± 0.024	≤ ± 0.011	≤ ± 0.018	≤ ± 0.011	
Temperature effect on minimum dead load output	%RO/°C	≤ ± 0.0040	≤ ± 0.0028	≤ ± 0.0012	≤ ± 0.0007	≤ ± 0.0012	≤ ± 0.0012	
Temperature effect on sensitivity	%/°C	≤ ± 0.0020	≤ ± 0.0016	≤ ± 0.0011	≤ ± 0.0011	≤ ± 0.0008	≤ ± 0.0008	
Excitation voltage	V	5...15						
Zero balance	%RO	≤ ± 1.0						
Input resistance	Ω	1106 ± 5						
Output resistance	Ω	1000 ± 1						
Insulation resistance	MΩ	≥ 5000						
Compensated temperature range	°C	-10...+40						
Operating temperature range	°C	-40...+80						
Safe load limit	%E _{max}	200						
Ultimate load	%E _{max}	300						
Safe side load	%E _{max}	100						
Load cell material		stainless steel 17-4 PH (1.4548)						
Sealing		complete hermetic sealing; cable entry sealed by glass to metal header						
Protection according DIN 40.050		IP 68						

* Available with E_{max} /20000 for 3-range scales.

Dimensions

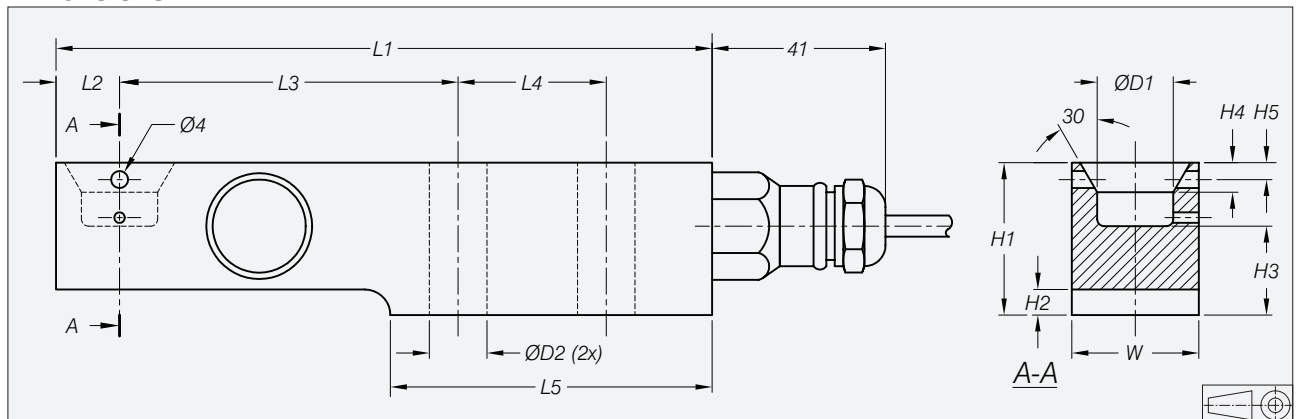

Type	L1	L2	L3	L4	L5	H1	H2	H3	H4	H5	W	D1	D2	Mounting bolts	Torque *
SB4-5 kN/10 kN/20 kN	155	15	80	35	76	36	6	21	7	4	30	18	13	M12 8.8	90 Nm
SB4-50 kN	190	21	105	40	93	49	8	28.5	6	8	43	25	21	M20 8.8	400 Nm
SB4-100 kN	245	30	135	50	120	73	12.5	42	10	n.a.	60	30	27	M24 8.8	700 Nm

All dimensions in mm. Dimensions and specifications are subject to change without notice.

* Torque values assume oiled threads.

Wiring

- The load cell is provided with a shielded, 4 conductor cable.
- Cable length: 3 m for SB4-5 kN/10 kN/20 kN, 4.5 m for SB4-50 kN/100 kN.
- Cable diameter: 5 mm.
- The shield is floating.

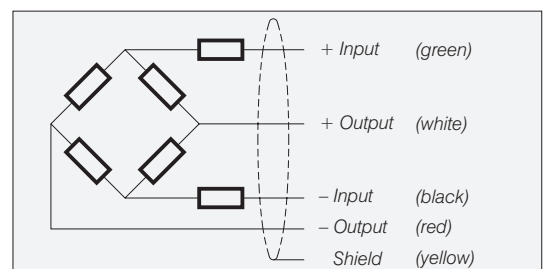

Type SB4 Load Cell, L-Version

The SB4 Load Cell, L-Version is available in the capacities 5 kN, 10 kN and 20 kN (510 kg, 1020 kg and 2039 kg). Available in Accuracy Classifications GP, C1, C3, C3 MI 7.5, C4 and C4 MI 7.5 according to OIML R 60.

For technical specifications, see SB4 brochure.

Especially designed for mobile weighing applications and/or extreme low profile scales.

Dimensions

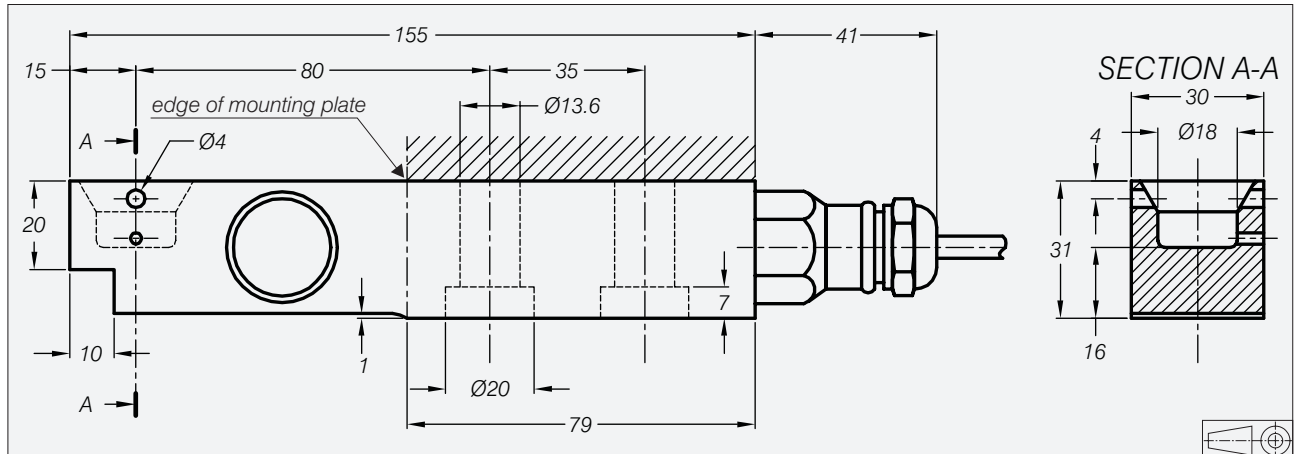

Application Example

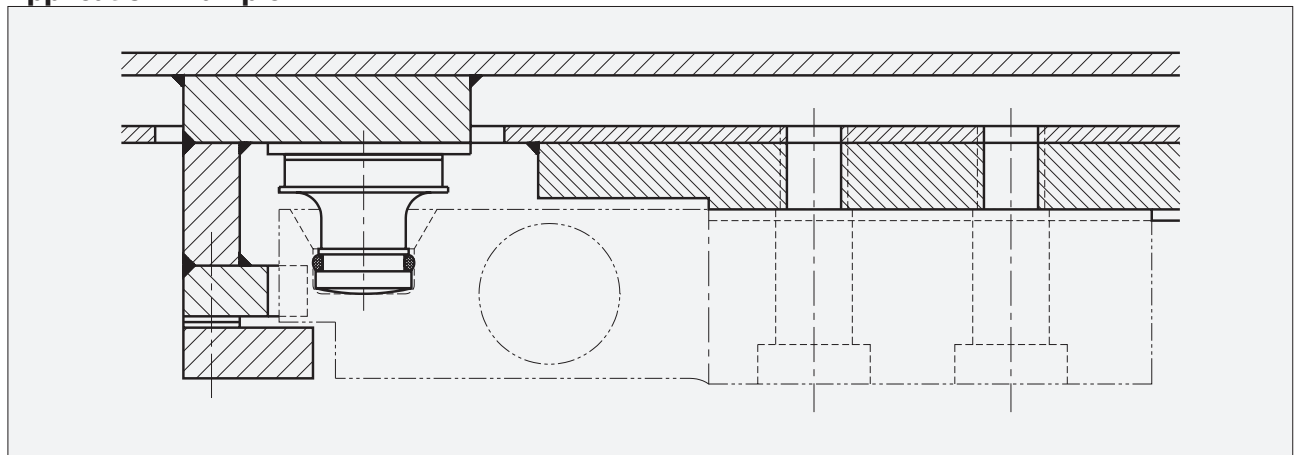

Example for mobile weighing.

L-Version load cell combined with sliding system, including integrated bumper stops and lift off protection.

Wiring

- The load cell is provided with a shielded, 4 conductor cable.
- Cable length: 1.9 m.
- Cable diameter: 5 mm.
- The shield is floating.

