

TESA CAL IP67 magna μ system

Patented measuring system – TESA magna μ system

New electronic caliper – The highest degree of protection ever achieved with hand-held tools of this type – Totally immune to the penetration of liquids and particles of metal.

Magnetic measuring system – a TESA's technology guaranteeing full reliability and accuracy, even in the toughest conditions of use – SWISS MADE.

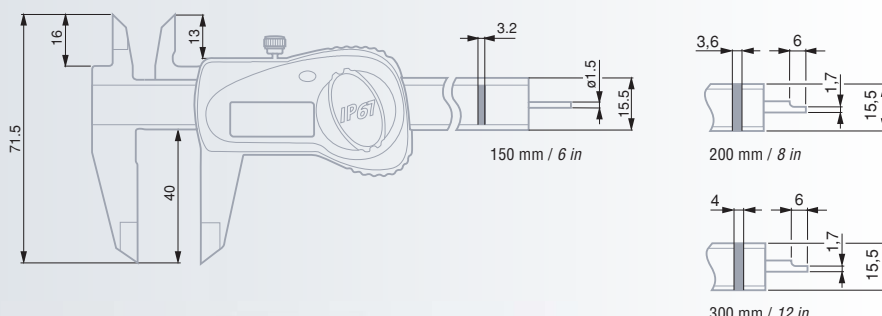
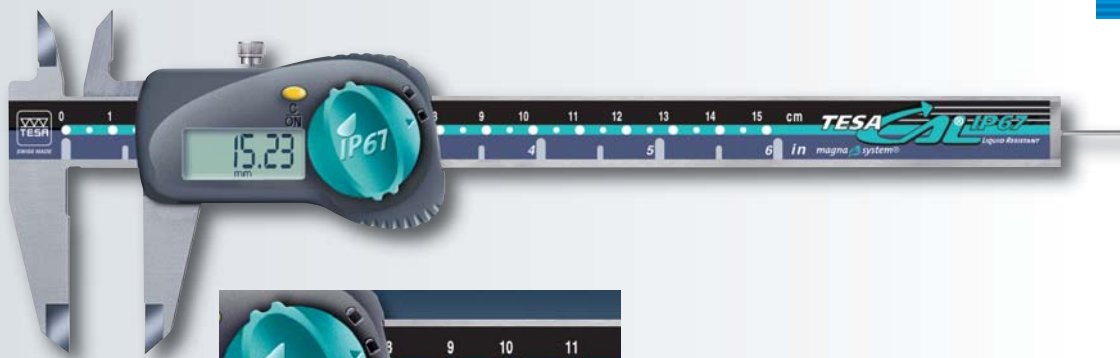

DIN 862 (Style 1A-ZS)

0,01 mm
0.0005 in

LCD, 7 mm

Floating zero

Conversion mm / in

≤100 mm = 20 μm
>100 mm = 30 μm

10 μm

Steel scale with incremental divisions, magnetic

> 1,8 m / s

RS232 opto-coupled, mono- and bi-directional

Hardened stainless steel

3V lithium battery, CR 2032

≈ 1,5 a (≈ 2000 h / a)

Idle mode after 10 min, automatic switch off after 2 h.

10°C to 40°C

-10°C to 60°C

100%

IP67 (IEC 60529)

EN 50081-1
EN 50082-1

Suited plastic case

Identification number

Inspection report with a declaration of conformity



	mm / in	RS232	Thumb roller	A mm	B mm	C mm	g
00530300	150 / 6	–	–	40	16	71,5	140
00530301	150 / 6	–	●	40	16	71,5	140
00530302	200 / 8	–	●	50	20	89,5	200
00530303	300 / 12	–	●	64	22	105,5	270
00530311	150 / 6	●	●	40	16	71,5	140
00530312	200 / 8	●	●	50	20	89,5	200
00530313	300 / 12	●	●	64	22	105,5	270

Optional Accessories

01961000 3 V lithium battery, 190 mAh, type CR 2032

00560013 Depth foot for calipers having a 150 mm measuring span (also see on page B-24)

For connecting cables, see section A





DIN 862
(Style E-ZS/B-ZS)

See table

0,01 mm
0.0005 in

LCD, 7 mm

Floating zero

Display lock

mm / in
conversion

See page B-2

Steel scale with
incremental
divisions, magnetic

> 1,8 m / s

RS232
opto-coupled,
mono- and
bi-directional

Hardened
stainless steel

3V lithium
battery, CR 2032

≈ 1,5 a
(≈ 2000 h / a)

Idle mode
after 10 min.,
automatic switch
off after 2 h.

10°C to 40°C

-10°C to 60°C

100%

IP67
(IEC 60529)

EN 50081-1
EN 50082-1

Wooden or
plastic case
depending on
the model

Identification
number

Inspection
report with a
declaration of
conformity

TESA IP67

Models with rounded measuring faces
for internal dimensions

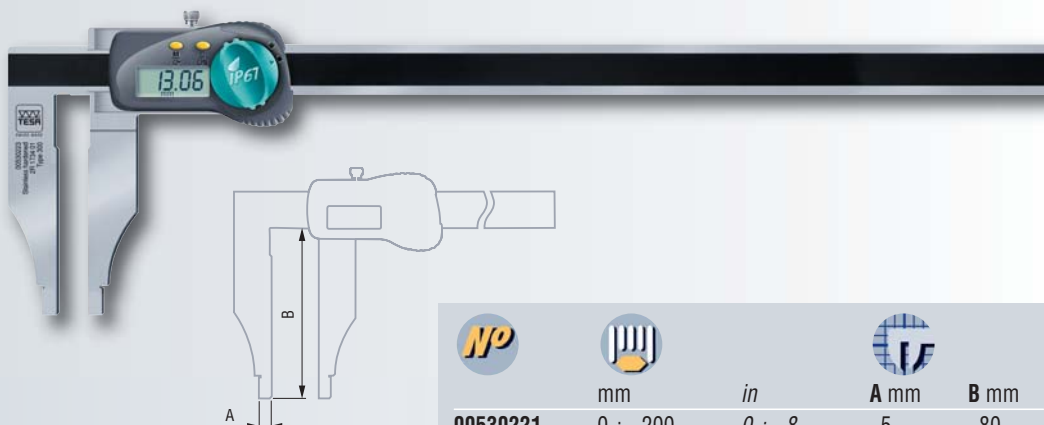

No	mm	in	A mm	B mm
00530221	0 ÷ 200	0 ÷ 8	5	80
00530222	0 ÷ 250	0 ÷ 10	5	80
00530223	0 ÷ 300	0 ÷ 12	5	90
00530224	0 ÷ 500	0 ÷ 20	10	150
00530225	0 ÷ 600	0 ÷ 24	10	150
00530226	0 ÷ 800	0 ÷ 32	10	150
00530227	0 ÷ 1000	0 ÷ 39	10	150

Optional Accessory

01961000 3V lithium battery, 190 mAh, type CR 2032
For connecting cables, see section A

Models with rounded measuring faces and knife-edge
jaws for both internal and external dimensions

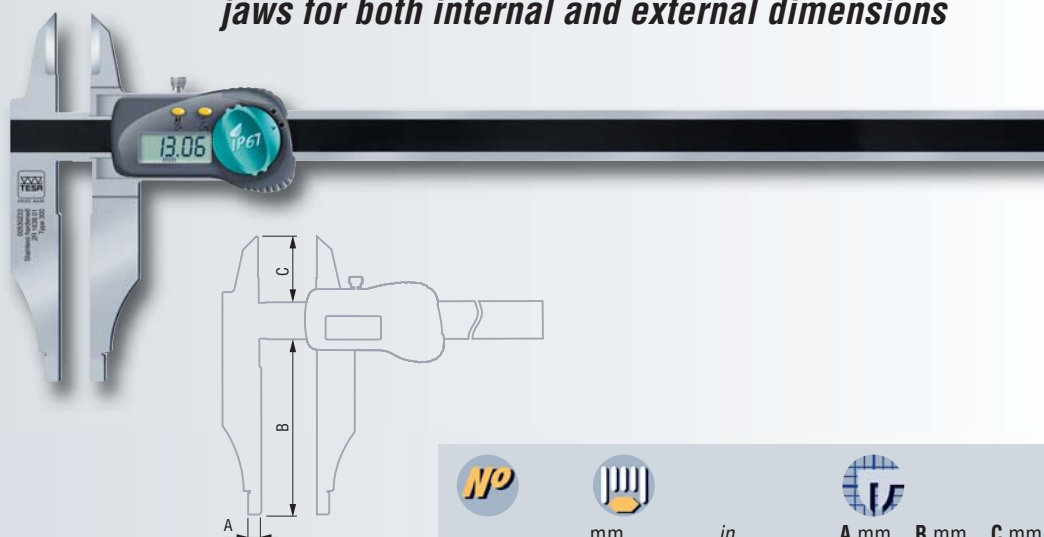

No	mm	in	A mm	B mm	C mm
00530231	0 ÷ 200	0 ÷ 8	5	80	30
00530232	0 ÷ 250	0 ÷ 10	5	80	37
00530233	0 ÷ 300	0 ÷ 12	5	90	37
00530234	0 ÷ 500	0 ÷ 20	10	150	60
00530235	0 ÷ 600	0 ÷ 24	10	150	60
00530236	0 ÷ 800	0 ÷ 32	10	150	56
00530237	0 ÷ 1000	0 ÷ 39	10	150	56

Optional Accessory

01961000 3V lithium battery, 190 mAh, type CR 2032
For connecting cables, see section A

Model with rounded measuring faces and knife-edge jaws for internal dimensions

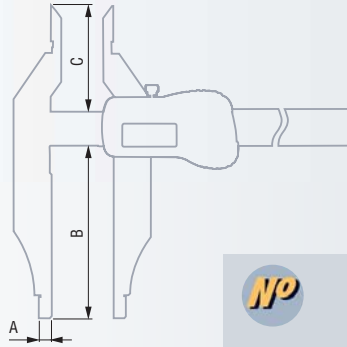
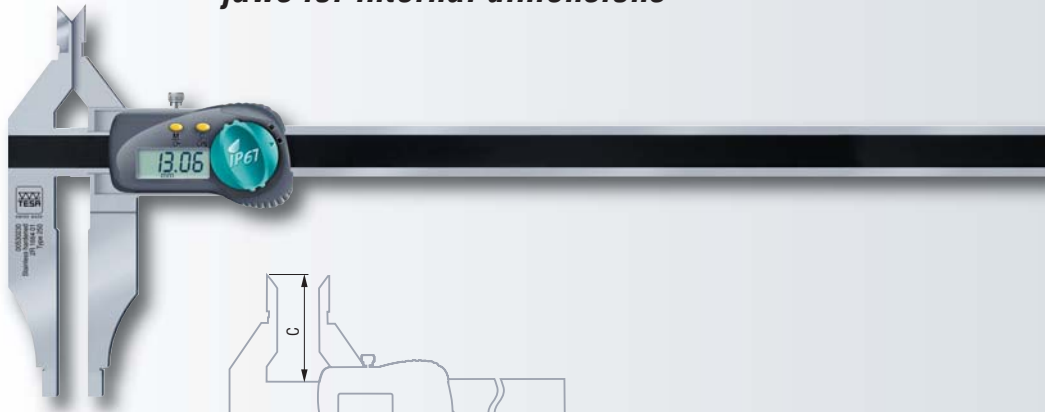

00530230		0 ÷ 250	0 ÷ 10	5	80	54
<i>Optional Accessory</i>						
01961000	3V lithium battery, 190 mAh, type CR 2032 For connecting cables, see section A					

- ✓
- DIN 862 (Style D-ZS)
- 0,01 mm
0.0005 in
- LCD, 7 mm
- Floating zero
- Display lock
- mm / in conversion
- See page B-2
- Steel scale with incremental divisions, magnetic
- > 1,8 m / s
- RS232 opto-coupled, mono- and bi-directional
- Hardened stainless steel
- 3V lithium battery, CR 2032
- ≈ 1,5 a
(≈ 2000 h / a)
- Idle mode after 10 min., automatic switch off after 2 h.
- 10°C to 40°C
- 10°C to 60°C
- 100%
- IP67 (IEC 60529)
- EN 50081-1
EN 50082-1
- Wooden case or plastic case depending on the model
- Identification number
- Inspection report with a declaration of conformity

TESA IP67

Models with short cut measuring faces or fixed jaws

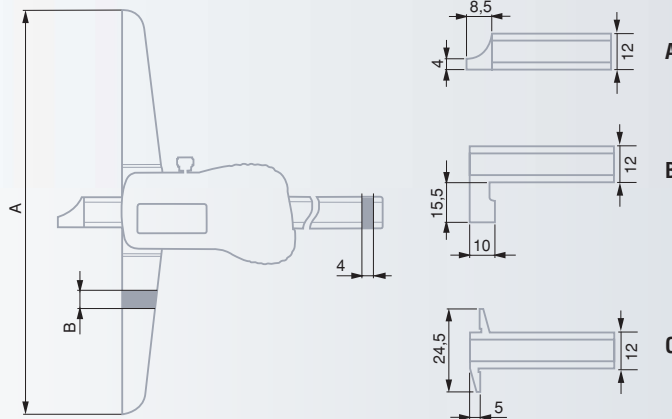
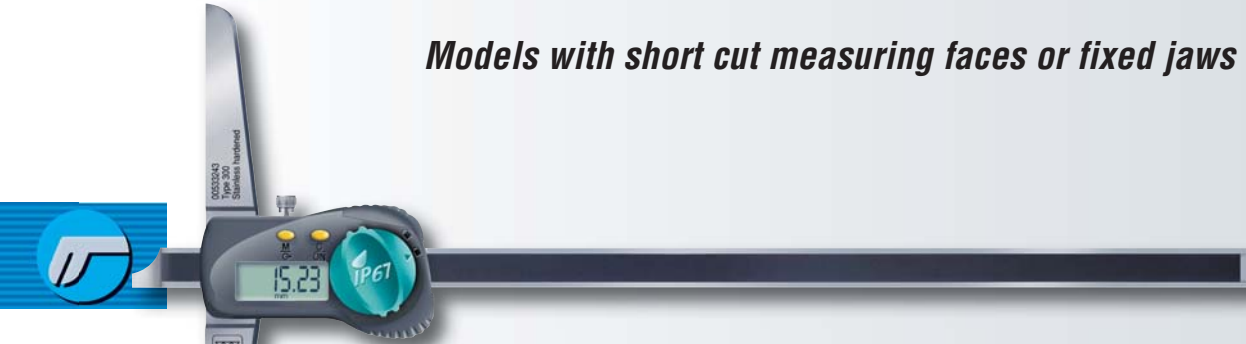

No	mm		in		A mm	B mm
	mm	in	mm	in		
Models A with a short cut measuring face						
00530241	0 ÷ 200	0 ÷ 8	100	8		
00530242	0 ÷ 250	0 ÷ 10	100	8		
00530243	0 ÷ 300	0 ÷ 12	150	8		
00530244	0 ÷ 500	0 ÷ 20	150	8		
Models B with one fixed jaw						
00530245	0 ÷ 300	0 ÷ 12	150	8		
00530246	0 ÷ 500	0 ÷ 20	150	8		
Models C with two fixed jaws						
00530247	0 ÷ 300	0 ÷ 12	150	8		
Optional Accessories						
	200, 300 or 400 mm removable bridge (see page B-19)					
01961000	3V lithium battery, 190 mAh, type CR 2032 For connecting cables, see section A					

- ✓
- DIN 862 (Style C-ZS)
- See table
- 0,01 mm
0.0005 in
- LCD, 7 mm
- Floating zero
- Display lock
- mm / in conversion
- See page B-2
- Glass scale with incremental divisions, magnetic
- > 1,8 m / s
- RS232 opto-coupled, mono- and bi-directional
- Hardened stainless steel
- 3V lithium battery, CR 2032
- ≈ 1,5 a
(≈ 2000 h / a)
- Idle mode after 10 min., automatic switch off after 2 h.
- 10°C to 40°C
- 10°C to 60°C
- 100%
- IP67 (IEC 60529)
- EN 50081-1
EN 50082-1
- Wooden case or plastic case depending on the model
- Identification number
- Inspection report with a declaration of conformity

Models with rotary stop plate

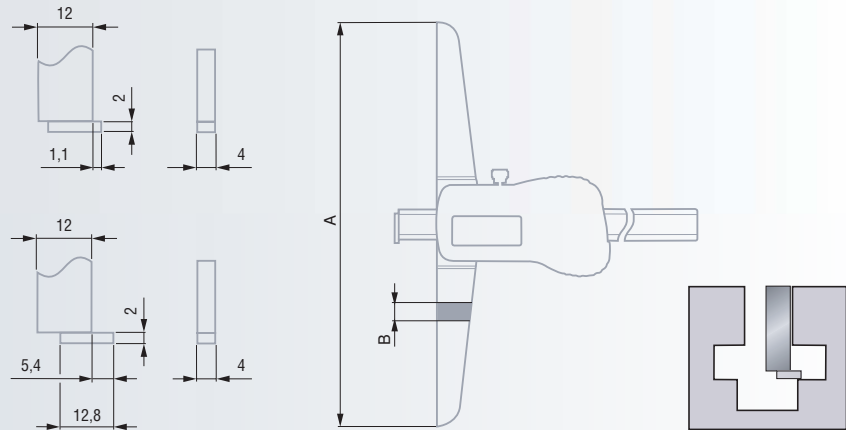
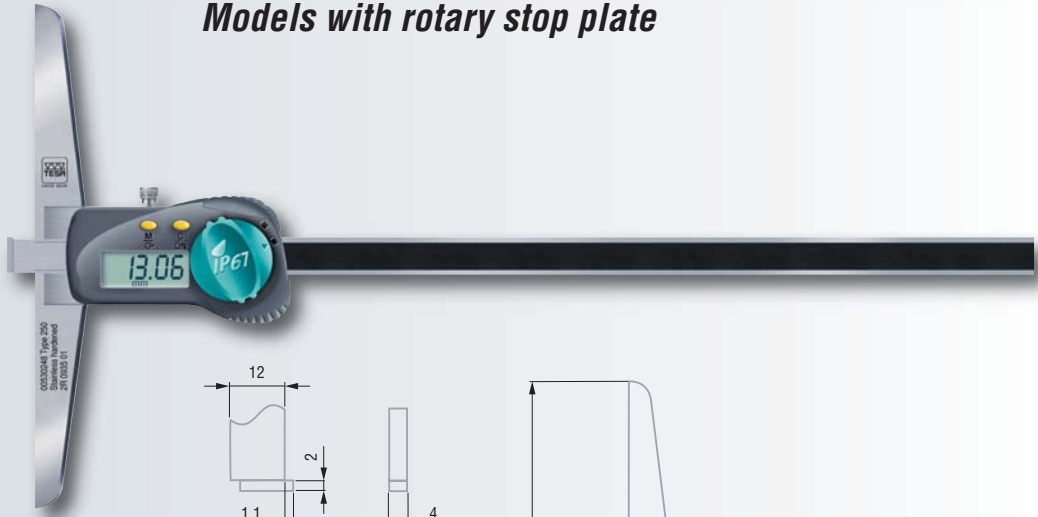

No	mm	in	A mm	B mm
00530248	0 ÷ 250	0 ÷ 10	150	8,5
00530249	0 ÷ 350	0 ÷ 14	150	8,5
00530250	0 ÷ 500	0 ÷ 20	150	8,5

Optional Accessories

	200, 300 or 400 mm removable bridge (also see page B-19)			
01961000	3V lithium battery, 190 mAh, type CR 2032			
	For connecting cables, see section A			

Small-sized caliper with measuring tip

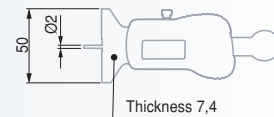

No	mm	in
00530251	0 ÷ 25	0 ÷ 1

Optional Accessory

01961000	3V lithium battery, 190 mAh, type CR 2032	
	For connecting cables, see section A	



DIN 862 (Style C-ZS)

See table

0,01 mm / 0,0005 in

LCD, 7 mm

Floating zero

Display lock

mm / in conversion

See page B-2

Steel scale with incremental divisions, magnetic

> 1,8 m / s

RS232 opto-coupled, mono- and bi-directional

Hardened stainless steel

3V lithium battery, CR 2032

≈ 1,5 a (≈ 2000 h / a)

Idle mode after 10 min, automatic switch off after 2 h.

10°C to 40°C

-10°C to 60°C

100%

IP67 (IEC 60529)

EN 50081-1 / EN 50082-1

Wooden case or plastic case depending on the model

Identification number

Inspection report with a declaration of conformity

Horizontal or Vertical Scale Unit

Lets you measure and position any assembly on fixtures, presetting devices for tooling or machines. Flexible mounting for use in any position.

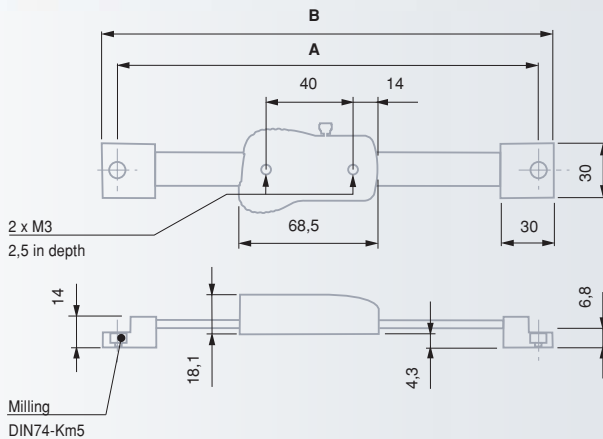

No	Scale		A mm	B mm
	mm	in		
00530271	0 ÷ 150	0 ÷ 6	265	278
00530273	0 ÷ 300	0 ÷ 12	415	428
00530274	0 ÷ 600	0 ÷ 24	725	738
00530275	0 ÷ 1000	0 ÷ 40	1135	1148

Optional Accessory

01961000	3V lithium battery, 190 mAh, type CR 2032 For connecting cables, see section A
----------	---

- ✓
- Factory standard
- See table
- 0,01 mm
0.0005 in
- LCD, 7 mm
- Floating zero
- Display lock
- mm / in conversion
- See page B-2
- Steel scale with incremental divisions, magnetic
- > 1,8 m / s
- RS232 opto-coupled, mono- and bi-directional
- Hardened stainless steel
- 3V lithium battery, CR 2032
- ≈ 1,5 a
(≈ 2000 h / a)
- Idle mode after 10 min., automatic switch off after 2 h.
- 10°C to 40°C
- 10°C to 60°C
- 100%
- IP67 (IEC 60529)
- EN 50081-1
EN 50082-1
- Suited carrying case
- Identification number
- Inspection report with a declaration of conformity